

**L** LABORATORY

**P** PROCESS

**S** SOFTWARE

**A** AUTOMATION

J 4 \$

0 M0F1SPDFTT4FOTPS  
GPS\$PMDH-VCSDBOUT



## SPECIFICATIONS

## IN-LINE PROCESS SENSOR - COOLING LUBRICANTS

|                        |   |
|------------------------|---|
| Measuring scales       | Cooling lubricant Scale %   |
| Measuring range        | 0 - 25 Brix   |
| Resolution             | 0.1 Brix  |
| Accuracy               | ± 0.3 Brix at 5°- 45° Celsius   |
| Temperature Accuracy   | +5 °C   |
| Temperature Resolution | ± 0,1°  |
| Process temperature    | +5° C to + 35°C   |
| Ambient temperature    | +10° C to + 40°C  |
| Max pressure           | 6 bar      10 bar < 12h   |
| Power supply           | 24 < 75mA (20V - 28V)   |
| Light source           | 589 nm LED  |
| Analog data output     | 4–20 mA - active output 300Ω, 2mA output if outside measuring ranges or error condition |
| Process condition      | optional: VariVent-Inline (Tuchenhagen) or APV-Inline (APV)                             |
| Other options          | Cleaning units (please contact SCHMIDT + HAENSCH for more detail)                       |
| Dimensions             | 165 mm x 45 mm ( length x diameter)   |
| Weight                 | 500 g   |

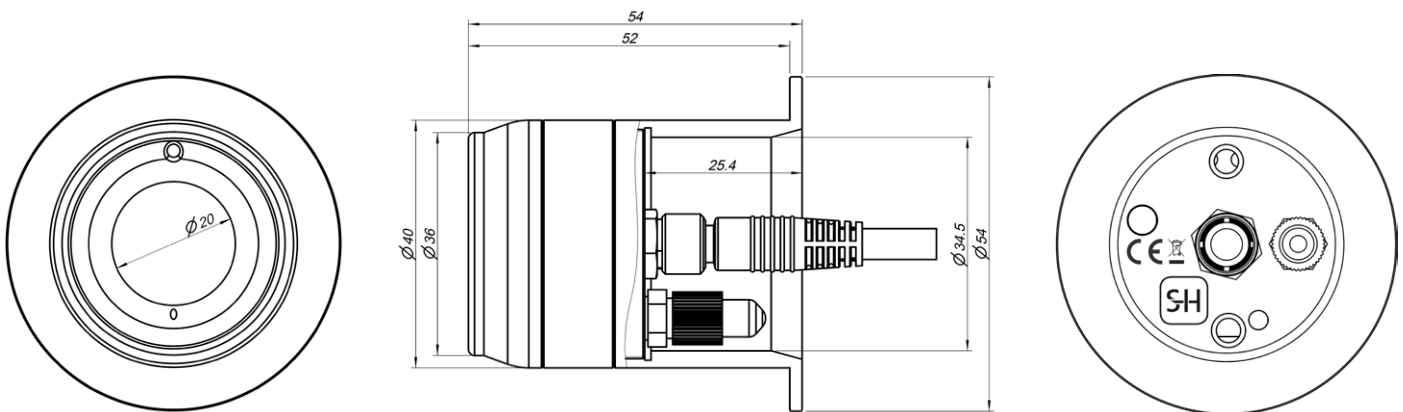

**SCHMIDT  
HAENSCH**  
innovators by tradition since 1864

SCHMIDT + HAENSCH GmbH & Co.  
Waldstraße 80-81, 13403 Berlin, Germany  
Tel: +49 (0 30) 417072-0, Fax: +49 (0 30) 417072-99  
sales@schmidt-haensch.de, www.schmidt-haensch.com



ISO 9001:2015